

INSTALLATION GUIDE - SERIES 009

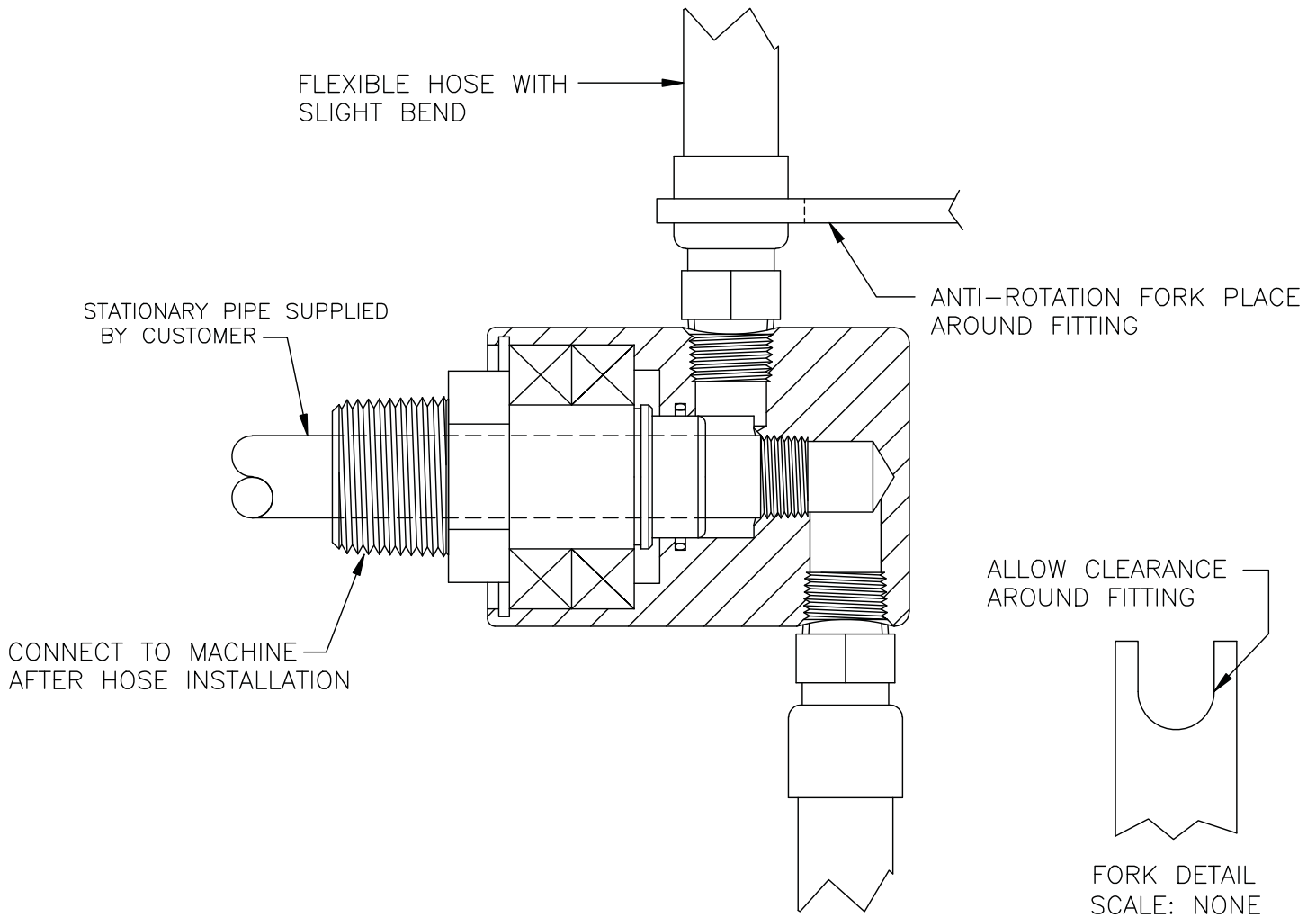

PROPER USE AND MOUNTING INSTRUCTIONS

1. Connect fitting to housing prior to threading union to machine.
 - Do not use rigid piping as this will compromise the life of the union.
 - The hose should be flexible and have a slight bend.
 - Extreme bends can reduce the flexibility of the hose.
 - The rubber hose selected should be able to safely handle the working pressure.
 - The hose should be properly supported & should not side load the union.
2. Thread stationary siphon pipe into housing through the shaft.
3. Connect male thread to machine using Teflon tape or pipe sealant.
4. Attach your preferred method of anti-rotation, such as a fork around the fitting. Anti-rotation must allow the union to find its center. Do not hard mount both the rotor and housing of the union.



ROTARY
SYSTEMS INC